

NOTE: ALL DIMENSIONS GIVEN IN THIS DRAWING ARE ESTIMATES, AND MAY VARY UP TO  $\pm 3$  INCHES. IF ANY DIMENSIONS ARE CRITICAL, PLEASE NOTIFY YOUR SALESPERSON.



THE INFORMATION CONTAINED IN THIS DOCUMENT IS THE SOLE PROPERTY OF MIDWEST FIRE (MWF). ANY REPRODUCTION IN PART OR AS A WHOLE WITHOUT THE WRITTEN PERMISSION OF MIDWEST FIRE IS STRICTLY PROHIBITED. THE DRAWING IS APPROXIMATE AND FOR REFERENCE PURPOSES ONLY. SPECIFICATIONS SHALL BE THE FINAL AUTHORITY DEFINING WHAT IS SUPPLIED ON THE APPARATUS.

PREPARED FOR  
SAUNDERS VOL. FIRE CO. INC.  
DRAWING NUMBER  
23053

BY  
B. JENSEN  
SHEET 1 OF 4

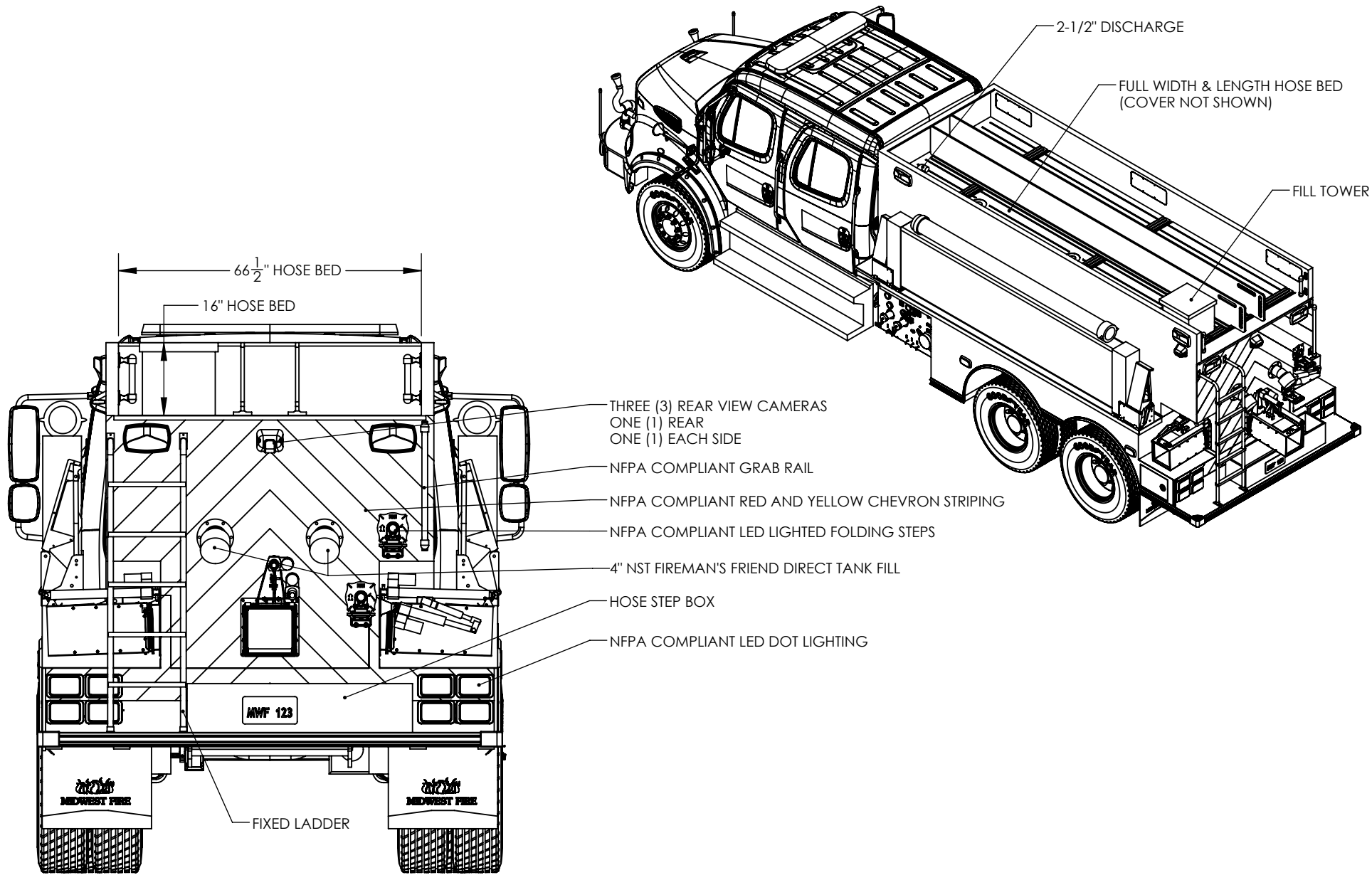

NOTE: ALL DIMENSIONS GIVEN IN THIS DRAWING ARE ESTIMATES, AND MAY VARY UP TO ±3 INCHES. IF ANY DIMENSIONS ARE CRITICAL, PLEASE NOTIFY YOUR SALESPERSON.



THE INFORMATION CONTAINED IN THIS DOCUMENT IS THE SOLE PROPERTY OF MIDWEST FIRE (MWF). ANY REPRODUCTION IN PART OR AS A WHOLE WITHOUT THE WRITTEN PERMISSION OF MIDWEST FIRE IS STRICTLY PROHIBITED. THE DRAWING IS APPROXIMATE AND FOR REFERENCE PURPOSES ONLY. SPECIFICATIONS SHALL BE THE FINAL AUTHORITY DEFINING WHAT IS SUPPLIED ON THE APPARATUS.

PREPARED FOR  
SAUNDERS VOL. FIRE CO. INC.  
DRAWING NUMBER  
23053

BY  
B. JENSEN  
SHEET 2 OF 4

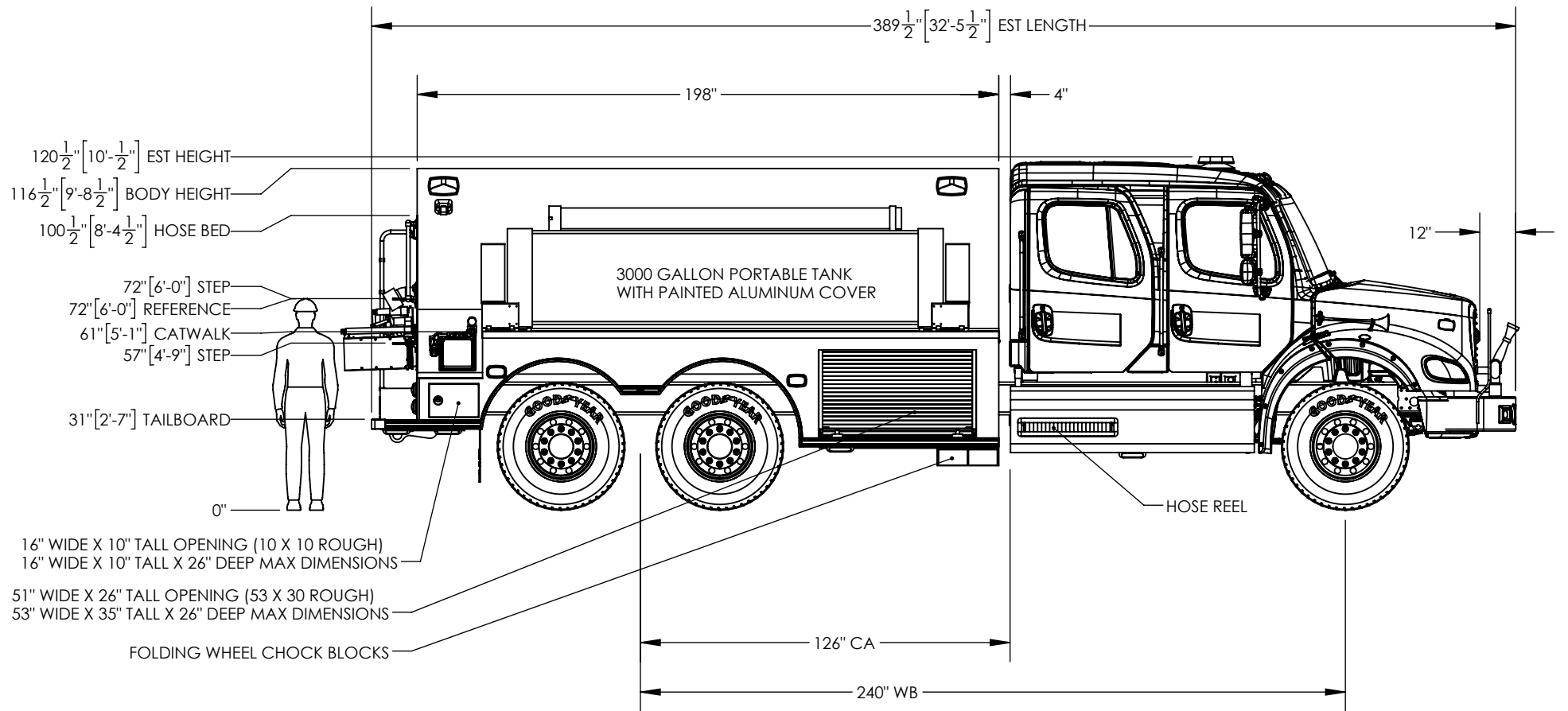

NOTE: ALL DIMENSIONS GIVEN IN THIS DRAWING ARE ESTIMATES, AND MAY VARY UP TO  $\pm 3$  INCHES. IF ANY DIMENSIONS ARE CRITICAL, PLEASE NOTIFY YOUR SALESPERSON.



THE INFORMATION CONTAINED IN THIS DOCUMENT IS THE SOLE PROPERTY OF MIDWEST FIRE (MWF). ANY REPRODUCTION IN PART OR AS A WHOLE WITHOUT THE WRITTEN PERMISSION OF MIDWEST FIRE IS STRICTLY PROHIBITED. THE DRAWING IS APPROXIMATE AND FOR REFERENCE PURPOSES ONLY. SPECIFICATIONS SHALL BE THE FINAL AUTHORITY DEFINING WHAT IS SUPPLIED ON THE APPARATUS.

PREPARED FOR  
SAUNDERS VOL. FIRE CO. INC.  
DRAWING NUMBER  
23053

BY  
B. JENSEN  
SHEET 3 OF 4

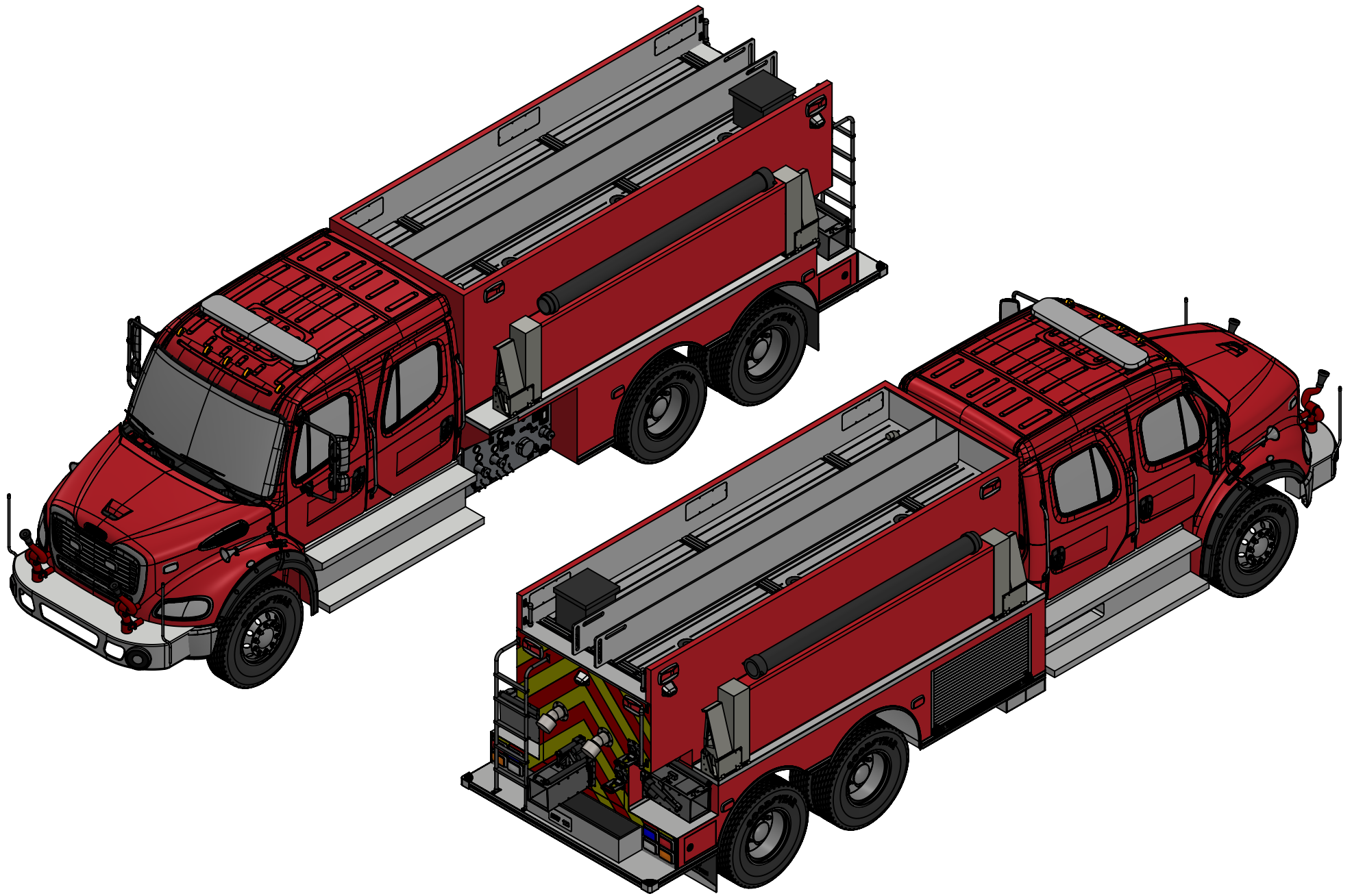

NOTE: ALL DIMENSIONS GIVEN IN THIS DRAWING ARE ESTIMATES, AND MAY VARY UP TO  $\pm 3$  INCHES. IF ANY DIMENSIONS ARE CRITICAL, PLEASE NOTIFY YOUR SALESPERSON.



THE INFORMATION CONTAINED IN THIS DOCUMENT IS THE SOLE PROPERTY OF MIDWEST FIRE (MWF). ANY REPRODUCTION IN PART OR AS A WHOLE WITHOUT THE WRITTEN PERMISSION OF MIDWEST FIRE IS STRICTLY PROHIBITED. THE DRAWING IS APPROXIMATE AND FOR REFERENCE PURPOSES ONLY. SPECIFICATIONS SHALL BE THE FINAL AUTHORITY DEFINING WHAT IS SUPPLIED ON THE APPARATUS.

PREPARED FOR  
SAUNDERS VOL. FIRE CO. INC.

DRAWING NUMBER  
23053

BY  
B. JENSEN

SHEET 4 OF 4